

SIZE CODE	Bore (B)		Groove (G)						Circlip (F)										Wt. (lb/k)	Tc† (lb.f)	Tg† (lb.f)
	B		G	Tol.	W	Tol.	n (min)	d	t	Tol.	D	Tol.	C	C1	L (max)	b ~	w ~	h (min)			
	(frac)	(dec)																			
0400	4	4.000	4.240		.120		.360	.120	.109		4.424		3.24	3.47	.378	.330	.166	.123	95.0	51400	27100
0412	4.1/8	4.125	4.365		.120		.360	.120	.109		4.558		3.36	3.60	.378	.330	.171	.123	97.0	53000	28000
0425	4.1/4	4.250	4.490		.120		.360	.120	.109		4.691		3.49	3.72	.378	.335	.180	.123	100	54600	28800
0433	—	4.331	4.571	±.006	.120		.360	.120	.109	±.003	4.756		3.50	3.73	.413	.345	.180	.151	107	55600	29400
0450	4.1/2	4.500	4.740		.120		.360	.120	.109		4.940		3.67	3.90	.413	.351	.181	.151	111	57800	30500
0462	4.5/8	4.625	4.865		.120		.360	.120	.109		5.076		3.79	4.03	.413	.360	.185	.151	119	59400	31400
0475	4.3/4	4.750	4.995		.120		.366	.122	.109	±.065	5.213		3.92	4.16	.413	.370	.175	.151	124	61000	32800
0500	5	5.000	5.260		.120		.390	.130	.109		5.485		4.10	4.36	.445	.395	.218	.151	136	64200	36800
0525	5.1/4	5.250	5.520		.139		.405	.135	.125		5.770		4.31	4.58	.465	.408	.212	.151	175	77300	40100
0537	5.3/8	5.375	5.650		.139		.405	.135	.125		5.910		4.44	4.71	.465	.408	.198	.151	179	78800	41000
0550	5.1/2	5.500	5.770	±.007	.139		.405	.135	.125	±.004	6.066		4.56	4.83	.465	.408	.200	.151	189	81000	42000
0575	5.3/4	5.750	6.020		.139		.405	.135	.125		6.336		4.81	5.08	.465	.408	.198	.151	195	84700	43900
0600	6	6.000	6.270		.139		.405	.135	.125		6.620		5.06	5.33	.465	.416	.223	.151	204	88400	45800
0625	6.1/4	6.250	6.530		.174		.420	.140	.156		6.895		5.34	5.61	.454	.441	.213	.182	263	114900	49500
0650	6.1/2	6.500	6.790		.174		.435	.145	.156		7.170		5.59	5.87	.454	.441	.244	.182	281	119500	53300
0662	6.5/8	6.625	6.925		.174		.450	.150	.156	±.080	7.308		5.71	6.01	.454	.441	.220	.182	300	121700	56200
0675	6.3/4	6.750	7.055		.174		.456	.152	.156		7.445		5.73	6.03	.508	.456	.224	.182	325	124000	58000
0700	7	7.000	7.315		.174		.471	.157	.156		7.720		5.91	6.22	.540	.485	.258	.182	344	128600	62200
0725	7.1/4	7.250	7.575		.209		.486	.162	.187		7.995		6.10	6.42	.570	.490	.238	.182	428	159700	66400
0750	7.1/2	7.500	7.840		.209		.510	.170	.187		8.270		6.35	6.69	.570	.507	.282	.182	476	165200	72100
0775	7.3/4	7.750	8.100	±.008	.209		.525	.175	.187	±.005	8.545		6.62	6.97	.560	.500	.241	.182	520	170700	76700
0800	8	8.000	8.360		.209		.540	.180	.187		8.820		6.79	7.15	.600	.550	.280	.182	555	152700	81400
0825	8.1/4	8.250	8.620		.209		.555	.185	.187		9.095		7.04	7.41	.600	.548	.260	.182	603	157500	86300
0850	8.1/2	8.500	8.880		.209		.570	.190	.187		9.285		7.23	7.60	.632	.573	.277	.182	634	162300	91300
0875	8.3/4	8.750	9.145		.209		.591	.197	.187		9.558		7.48	7.88	.632	.576	.283	.182	653	167000	97700
0900	9	9.000	9.405		.209		.606	.202	.187		9.830		7.73	8.13	.632	.592	.294	.182	732	171800	103000
0925	9.1/4	9.250	9.668		.209		.627	.209	.187		10.102		7.98	8.39	.632	.622	.299	.182	767	176600	109000
0950	9.1/2	9.500	9.930		.209		.645	.215	.187		10.375		8.23	8.65	.632	.622	.354	.182	803	181400	116000
0975	9.3/4	9.750	10.190		.209		.660	.220	.187		10.648		8.50	8.93	NO LUG	.622	.295	.182	833	186200	121300
1000	10	10.000	10.450		.209		.675	.225	.187		10.920		8.75	9.19	NO LUG	.622	.295	.182	863	191000	127200

Standard External Circlips American Specification *

N14 Equivalent to MIL-R-21248/MS 16624

All dimensions in inches

*These circlips should not be used as direct substitutes for British Standard Imperial sizes

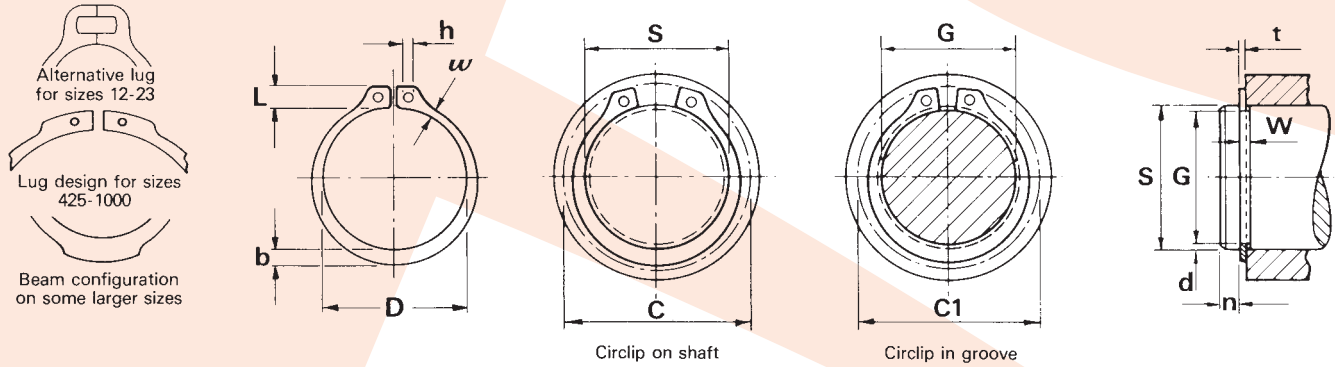

*Sizes 12-23 Beryllium copper only

SIZE CODE	Shaft (S)		Groove (G)						Circlip (F)										Wt. (lb/k)	Tc† (lb.f)	Tg† (lb.f)
	S		G	Tol.	W	Tol.	n (min)	d	t	Tol.	D	Tol.	C	C1	L (max)	b ~	w ~	h (min)			
	(frac)	(dec)																			
*0012	1/8	.125	.117		.012		.014	.004	.010	±.001	.112		.22	.214	.048	.018	.011	.024	0.018	110	28
*0015	5/32	.156	.146		.012		.017	.005	.010		.142		.27	.260	.056	.026	.016	.024	0.037	130	44
*0018	3/16	.188	.175		.018	+ .002	.022	.007	.015		.168		.30	.286	.052	.025	.016	.023	0.059	240	69
*0019	—	.197	.185	±.0015	.018	— .000	.020	.006	.015		.179		.32	.307	.058	.026	.016	.024	0.063	250	67
*0021	7/32	.219	.205		.018		.023	.007	.015		.196		.34	.324	.058	.028	.017	.024	0.074	280	87
*0023	15/64	.236	.222		.018		.023	.007	.015		.215		.36	.341	.058	.030	.019	.024	0.086	310	93
0025	1/4	.250	.230		.029		.032	.010	.025		.225		.45	.43	.083	.035	.025	.039	0.21	880	141
0027	—	.276	.255		.029		.035	.010	.025		.250		.48	.46	.084	.035	.024	.039	0.25	980	164
0028	9/32	.281	.261		.029		.033	.010	.025	±.002	.256		.49	.47	.083	.038	.025	.039	0.24	990	160
0031	5/16	.312	.290		.029		.036	.011	.025		.281		.54	.52	.090	.040	.026	.039	0.27	1100	194
0034	11/32	.344	.321	±.002	.029	+ .003	.038	.012	.025		.309		.57	.55	.090	.042	.026	.039	0.31	1210	224
0035	—	.354	.330		.029	— .000	.038	.012	.025		.320		.59	.57	.090	.046	.029	.039	0.35	1250	240
0037	3/8	.375	.352		.029		.038	.012	.025		.338		.61	.59	.091	.050	.030	.039	0.39	1320	244
0039	—	.394	.369		.029		.041	.013	.025		.354		.62	.60	.090	.052	.031	.039	0.42	1390	278
0040	13/32	.406	.382		.029		.039	.012	.025		.366		.63	.61	.090	.054	.033	.039	0.43	1430	275

Standard material - carbon spring steel. Standard finish - phosphate and oil.

SIZE CODE	Shaft (S)		Groove (G)						Circlip (F)								Wt. (lb/k)	Tc† (lb.f)	Tg† (lb.f)		
	S		G	Tol.	W	Tol.	n (min)	d ~	t	Tol.	D	Tol.	C	C1	L (max)	b ~				w ~	h (min)
	(frac)	(dec)																			
0043	7/16	.438	.412		.029		.042	.013	.025		.395	+ .002	.66	.64	.091	.055	.033	.039	0.50	1550	322
0046	15/32	.469	.443		.029		.042	.013	.025		.428	- .005	.68	.66	.091	.060	.035	.039	0.54	1660	345
0050	1/2	.500	.468	± .002	.039		.051	.016	.035		.461		.77	.74	.111	.065	.040	.045	0.91	2470	452
0055	—	.551	.519		.039		.051	.016	.035		.509		.81	.78	.111	.053	.036	.045	0.90	2730	500
0056	9/16	.562	.530		.039		.051	.016	.035		.521		.82	.79	.111	.072	.041	.045	1.10	2780	508
0059	19/32	.594	.559		.039		.057	.017	.035		.550		.86	.83	.112	.076	.043	.045	1.20	2940	588
0062	5/8	.625	.588		.039		.060	.018	.035		.579		.90	.87	.113	.080	.045	.045	1.30	3090	654
0066	43/64	.672	.631		.039		.066	.020	.035		.621		.93	.89	.113	.082	.043	.045	1.40	3320	780
0068	11/16	.688	.646		.046	+ .003	.068	.021	.042		.635	+ .005	1.01	.97	.140	.084	.048	.050	1.80	4080	817
0075	3/4	.750	.704		.046		.074	.023	.042		.693	- .010	1.09	1.05	.140	.092	.051	.050	2.10	4450	975
0078	25/32	.781	.733	± .003	.046		.076	.024	.042		.722		1.12	1.08	.140	.094	.052	.050	2.2	4600	1060
0081	13/16	.812	.762		.046		.080	.025	.042		.751		1.15	1.10	.140	.096	.054	.050	2.5	4800	1150
0087	7/8	.875	.821		.046		.085	.027	.042	± .002	.810		1.21	1.16	.141	.104	.057	.050	2.8	5200	1340
0093	15/16	.938	.882		.046		.088	.028	.042		.867		1.34	1.29	.170	.110	.063	.076	3.1	5600	1480
0098	63/64	.984	.926		.046		.091	.029	.042		.910		1.39	1.34	.171	.114	.065	.076	3.5	5800	1610
0100	1	1.000	.940		.046		.094	.030	.042		.925		1.41	1.35	.171	.116	.065	.076	3.6	5900	1700
0102	—	1.023	.961		.046		.097	.031	.042		.946		1.43	1.37	.172	.118	.066	.076	3.9	6100	1790
0106	1.1/16	1.062	.998		.056		.102	.032	.050		.982		1.50	1.44	.185	.122	.069	.076	4.8	7500	1920
0112	1.1/8	1.125	1.059		.056		.105	.033	.050		1.041		1.55	1.49	.186	.128	.071	.076	5.1	7900	2100
0118	1.3/16	1.188	1.118		.056		.111	.035	.050		1.098		1.61	1.54	.186	.132	.072	.076	5.6	8400	2350
0125	1.1/4	1.250	1.176	± .004	.056		.117	.037	.050		1.156	+ .010	1.69	1.62	.187	.140	.076	.076	5.9	8800	2610
0131	1.5/16	1.312	1.232		.056		.126	.040	.050		1.214	- .015	1.75	1.67	.187	.146	.077	.076	6.8	9300	2970
0137	1.3/8	1.375	1.291		.056		.132	.042	.050		1.272		1.80	1.72	.188	.152	.082	.076	7.2	9700	3270
0143	1.7/16	1.438	1.350		.056		.138	.044	.050		1.333		1.87	1.79	.188	.160	.086	.076	8.1	10200	3580
0150	1.1/2	1.500	1.406		.056	+ .004	.147	.047	.050		1.387		1.99	1.90	.218	.168	.091	.118	9.0	10600	3990
0156	1.9/16	1.562	1.468		.068	- .000	.148	.047	.062		1.446		1.95	1.85	.189	.180	.098	.100	11.7	10700	4150
0162	1.5/8	1.625	1.529		.068		.151	.048	.062		1.503		2.17	2.08	.189	.180	.097	.100	12.8	11100	4410
0168	1.11/16	1.688	1.589		.068		.156	.049	.062		1.560		2.04	1.95	.205	.197	.099	.100	13.2	11500	4720
0175	1.3/4	1.750	1.650		.068		.157	.050	.062		1.618	+ .013	2.11	2.01	.205	.197	.101	.100	13.8	11900	4950
0177	—	1.772	1.669	± .005	.068		.162	.051	.062		1.618	- .020	2.19	2.09	.205	.197	.102	.100	14.1	12100	5160
0181	1.13/16	1.812	1.708		.068		.163	.052	.062		1.675		2.23	2.13	.205	.197	.095	.100	14.7	12400	5330
0187	1.7/8	1.875	1.769		.068		.166	.053	.062		1.735		2.29	2.19	.205	.197	.104	.100	15.5	12800	5620
0196	—	1.968	1.857		.068		.174	.055	.062		1.819		2.39	2.27	.205	.197	.106	.123	18.2	13400	5170
0200	2	2.000	1.886		.068		.178	.057	.062		1.850		2.48	2.36	.232	.224	.108	.123	19.2	13600	6450
0206	2.1/16	2.062	1.946		.086		.183	.058	.078		1.906		2.52	2.40	.225	.217	.111	.123	22.6	17700	6760
0212	2.1/8	2.125	2.003		.086		.192	.061	.078		1.964		2.61	2.48	.236	.228	.120	.123	24.4	18200	7330
0215	2.5/32	2.156	2.032		.086		.195	.062	.078		1.993		2.62	2.49	.225	.217	.113	.123	26.6	18500	7560
0225	2.1/4	2.250	2.120		.086		.204	.065	.078		2.081		2.87	2.74	.225	.217	.116	.123	26.0	19300	8270
0231	2.5/16	2.312	2.178		.086		.210	.067	.078		2.139	- .025	2.94	2.81	.225	.217	.118	.123	28.4	19800	8760
0237	2.3/8	2.375	2.239		.086		.213	.068	.078		2.197		2.86	2.72	.236	.228	.119	.123	27.9	20400	9130
0243	2.7/16	2.438	2.299		.086		.217	.069	.078		2.255		2.92	2.78	.236	.228	.120	.123	29.4	20900	9580
0250	2.1/2	2.500	2.360		.086		.219	.070	.078		2.313		2.98	2.84	.236	.228	.122	.123	29.7	21400	9900
0255	—	2.559	2.419		.086		.219	.070	.078		2.377		3.09	2.94	.258	.250	.130	.123	31.7	21900	10100
0262	2.5/8	2.625	2.481		.086		.225	.072	.078		2.428		3.11	2.96	.236	.228	.120	.123	35.0	22500	10700
0268	2.11/16	2.688	2.541		.086		.230	.073	.078		2.485		3.32	3.18	.273	.246	.129	.123	36.0	23000	11200
0275	2.3/4	2.750	2.602		.103		.231	.074	.093	± .003	2.543		3.33	3.18	.284	.276	.145	.123	47.0	28100	11500
0287	2.7/8	2.875	2.721		.103		.240	.077	.093		2.659		3.42	3.26	.268	.260	.133	.123	48.4	29400	12500
0293	2.15/16	2.938	2.779		.103		.247	.079	.093		2.717		3.49	3.32	.268	.260	.125	.123	50.0	30000	13200
0300	3	3.000	2.838		.103		.252	.081	.093		2.775		3.55	3.38	.268	.260	.138	.123	51.5	30700	13700
0306	3.1/16	3.062	2.898		.103	+ .005	.255	.082	.093		2.832		3.61	3.44	.268	.260	.131	.123	56.8	31300	14200
0312	3.1/8	3.125	2.957	± .006	.103		.261	.084	.093		2.892		3.75	3.57	.305	.272	.141	.123	57.9	32000	14800
0315	3.5/32	3.156	2.986		.103		.264	.085	.093		2.920		3.74	3.56	.284	.276	.143	.123	59.0	32300	15200
0325	3.1/4	3.250	3.076		.103		.270	.087	.093		3.006		3.83	3.65	.284	.276	.145	.123	61.9	33200	16000
0334	3.11/32	3.346	3.166		.103		.279	.090	.093		3.092		3.93	3.74	.284	.276	.147	.123	63.9	34200	17000
0343	3.7/16	3.438	3.257		.103		.280	.090	.093		3.179	+ .020	4.02	3.83	.284	.276	.130	.123	65.9	35200	17600
0350	3.1/2	3.500	3.316		.120		.285	.092	.109		3.237		4.15	3.96	.320	.285	.148	.123	71.9	42000	18200
0354	—	3.543	3.357		.120		.288	.093	.109		3.277		4.20	4.00	.320	.288	.149	.123	72.9	42500	18600
0362	3.5/8	3.625	3.435		.120		.294	.095	.109		3.352		4.28	4.09	.323	.315	.153	.123	76.0	43400	19500
0368	3.11/16	3.688	3.493		.120		.301	.097	.109		3.410		4.31	4.11	.335	.302	.156	.123			